

# Model 350 Series Triplex Plunger Pump

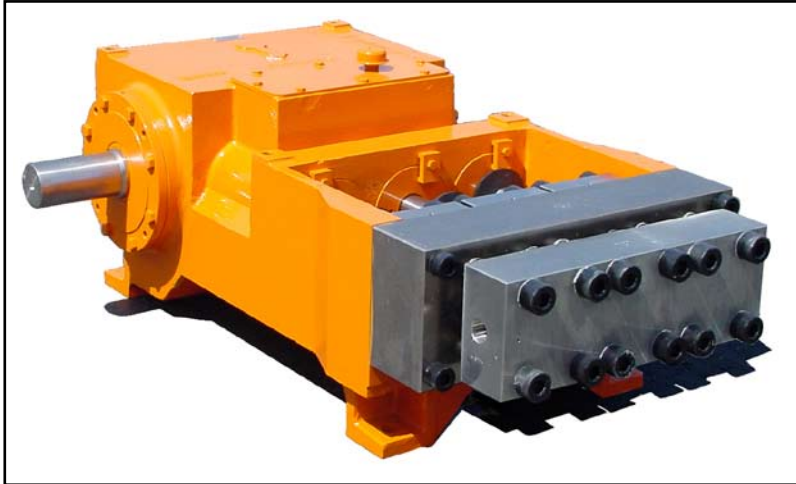

## SPECIFICALLY DESIGNED FOR HIGH-PRESSURE PUMPING APPLICATIONS.

The NLB 350 Series pump is an advanced-design triplex pump with exceptional flexibility and versatility to efficiently meet the requirements of a wide range of pumping services. The unit features a simple, rugged design to meet the heavy-duty requirements of continuous operation and to minimize maintenance.

## FLUID END DESIGNED TO RESIST HIGH PRESSURE AND HYDRAULIC SHOCK.

- Fluid cylinder machined from carbon steel with electroless nickel plate. Passages are drilled to minimize turbulence. Design features minimum volumetric clearance and stress, with maximum shock and pressure resistance.
- Stainless steel valves have a rugged wing guided design. Seats are beveled and are also made from hardened stainless steel.
- Packing and plungers can be removed for inspection or replacement without removing the stuffing box.

- Packing assemblies are spring-loaded and self-adjusting for extended life.
- Connections for plunger lubrication at atmospheric pressure.
- Colomony®-coated plungers.

## PROVEN, HEAVY-DUTY INDUSTRIAL POWER FRAME.

- Horizontal configuration provides easy access and low center of gravity.
- Massive, cast-iron housing with gravity lubrication and large oil reservoir.
- Steel crankshaft mounted in tapered roller bearings. Symmetrical design permits easy conversion to opposite-hand drive.
- Marine-type connecting rods with split, babbitted rod bearings and sleeve-type bronze wrist bearings. All under compressive loading only.
- Large-diameter cylinder crossheads operating in full circular guides, fitted with hardened wrist pins.
- Ground crosshead stub shafts with lipped seals to keep water and dust out of crankcase.
- High mechanical efficiency.
- Plunger cover for cleanliness and operator protection.

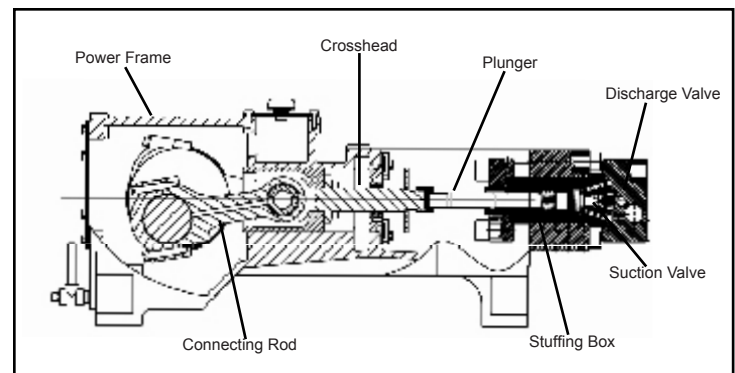

Colomony® is a registered trademark of Wall Colmonoy Corporation.

# PUMP DISPLACEMENT— GPM (LPM)

A-CYLINDER	PLUNGER DIA.		PUMP RPM										MAX. PRESSURE	
	IN	MM	100		200		300		400		411 (350 HP)		PSI	BAR
			GPM	LPM	GPM	LPM	GPM	LPM	GPM	LPM	GPM	LPM		
	1-1/5	30.5	7.31	27.66	14.61	55.32	21.92	82.98	29.23	110.64	30.00	113.56	20,000	1,400
	1-1/4	31.8	8.59	32.52	17.18	65.05	25.78	97.57	34.37	130.09	35.00	132.49	17,000	1,173
	1-3/8	34.9	9.74	36.87	19.48	73.75	29.22	110.62	38.96	147.49	40.00	151.41	15,000	1,035
	1-1/2	38.1	11.48	43.44	22.95	86.87	34.43	130.31	45.90	173.75	47.00	177.91	13,000	896
	1-11/16	42.9	14.52	54.97	29.05	109.95	43.57	164.92	58.09	219.90	60.00	227.12	10,000	700
	1-7/8	47.6	17.93	67.87	35.86	135.74	53.79	203.61	71.72	271.48	74.00	280.11	8,000	552
	2-3/16	55.6	24.35	92.17	48.70	184.35	73.05	276.52	97.40	368.69	100.00	378.53	6,000	414

Actual pump capacity is approximately 92% of the displacement.

Horsepower can be computed by using the formula:  $BHP = \frac{GPM \times PSI}{1715}$

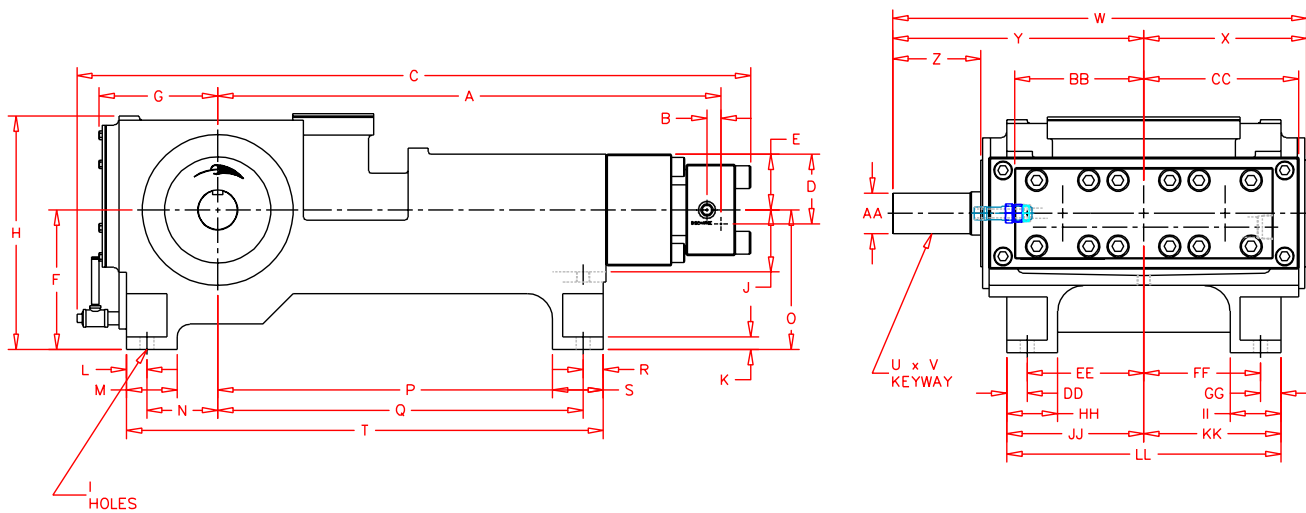

IN	A	B	C	D	E	F	G	H	I	J	K	L	M	N	O	P	Q	R	S
	49-19/32	1-3/8	66-13/32	6-7/8	5-1/2	13-3/4	11-11/16	23	1-3/8	6-1/8	1-1/4	2	5	7	13-3/4	38	36	2	5
MM	1259.7	35	1686.8	174.7	139.7	349.3	296.9	584.2	35	155.6	31.8	50.8	127	177.8	349.3	965.2	914.4	50.8	127
IN	T	U	V	W	X	Y	Z	AA	BB	CC	DD	EE	FF	GG	HH	II	JJ	KK	LL
	47	1	1/2	40-13/16	16-1/16	24-3/4	8-11/16	4	12-3/4	15-1/4	2	11-1/2	11-1/2	2	5	5	13-1/2	13-1/2	27
MM	1193.8	25.4	12.7	1036.7	408	638.2	220.7	101.6	323.9	387.4	50.8	292.1	292.1	50.8	127	127	342.9	342.9	685.8

Specifications are subject to change without notice.

©Copyright 2003 NLB Corporation

**NLB Corp.**  
The Leader in High-Pressure  
Water Jet Technology

**Headquarters**  
29830 Beck Road  
Wixom, MI 48393-2824  
(248) 624-5555  
FAX: (248) 624-0908  
<http://www.nlbcorp.com>

**Regional Offices**

- 159 Harmony Road, Mickleton, NJ 08056 (856) 423-2211 FAX: (856) 423-0997
- 14302 Highway 44 N., Gonzales, LA 70737 (225) 622-1666 FAX: (225) 622-7366
- 11506 Spencer Hwy, La Porte, TX 77571 (281) 471-7761 FAX: (281) 471-8738
- 1323 E. Hill St., Signal Hill, CA 90755 (562) 490-3277 FAX: (562) 733-0780